

EDtapper

EDM TAPPING ACCESSORY

PAT. PEND

USER'S MANUAL

Tapping Equipment for a
Sinker Erosion Machine (EDM)

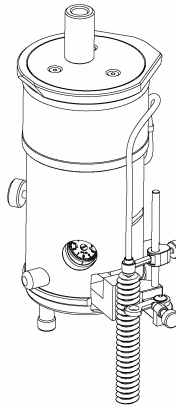

DOC. P/N: EDH2F01 MM Ver - 3

THIS DOCUMENT CONTAINS PROPRIETARY INFORMATION OF SHILO TECHNOLOGIES LTD., AND MAY NOT BE REPRODUCED, COPIED, DISCLOSED OR UTILIZED IN ANY WAY, IN WHOLE OR IN PART, WITHOUT THE PRIOR WRITTEN CONSENT OF SHILO TECHNOLOGIES LTD.

SHILO TECHNOLOGIES LTD.

www.ed-tapper.com

FOREWORD

The purpose of this manual is to help the user understand and properly operate the **EDM Tapping Accessory**. User must become familiar with the instructions in this manual to ensure reliable system operation.

Table of Contents

<u>Paragraph</u>	<u>Page</u>
CHAPTER 1 - INTRODUCTION	1
1-1. System Description.....	1
CHAPTER 2 - OPERATING INSTRUCTIONS.....	8
2-1. Normal Operational Procedure.....	8
2-1.1 General	8
2-2. Special Operational Procedure	16
2-2.1 Adjusting The Blade For The Thread Pitch.....	16
2-2.2 Linear Motion Parallel To A Radial Alignment Surface	18
2-2.3 Forming Cavities With A Circular Symmetry Using Flat Electrode With A Profile	19
2-2.4 Partial (Less Than 360°) Sector Etching.....	21
2-2.5 Creation of Threads Using Short Electrode.....	21
CHAPTER 3 - CAUTIONS AND LIMITATION OF WARRANTY	22
CHAPTER 4 - WARRANTY	24

List of Figures

<u>Figure</u>	<u>Page</u>
Figure 1. EDTapper Accessory Description.....	4
Figure 2. EDTapper Kit Contents.....	5
Figure 3. EDTapper Technical Specifications.....	6
Figure 4. EDTapper Operation	9
Figure 5. Blade Engaged in Electrode's Groove.....	16
Figure 6. Thread Pitch Blade Adjustment	17
Figure 7. Linear Motion Parallel To A Radial Alignment Surface.....	18
Figure 8. Forming Cavities With A Circular Symmetry Using Flat Electrode With A Profile	20
Figure 9. Using Collet Chuck.....	21

Chapter 1

INTRODUCTION

1-1. System Description

With sinker erosion machines only vertical cavities can be formed. The electrode is usually attached to the machine head and it moves on the Z-axis in the direction of the material and etches a cavity according to the shape of the electrode. These machines do not permit cavities to be formed that penetrate horizontally into the material by more than the entry opening (undercutting) such as an inverted cone, a graduated hole the diameter of which is greater in the bottom part, a groove for a retaining ring (circlip) or an O-ring, a tapping or gripping sockets to ensure extraction of parts from injection moulds. Likewise, an existing cylindrical hole can not be enlarged except by using a larger electrode. CNC erosion machine is needed to implement these operations.

The EDtapper enables these operations to be carried out on ordinary erosion machines. It is mounted on the machine head as simply as an electrode and does not require any interference with the electronic operating system of the machine. **The operation of the accessory is implemented when the base foot at its bottom contacts the table of the machine** (or a static body that is placed on the table of the machine), and the machine's motion on the Z-axis contracts the accessory against an internal spring (with a load of 8 kg when, with most of the machines, the permitted load on the head exceeds 25 kg). While the accessory is contracting, the vertical motion is converted to an orbital one so that with a movement of 40 mm on the Z-axis the electrode holder completes a whole turn. The head should be allowed to make a 42 mm movement in order to ensure a clean conjunction between the beginning and the end of the turn.

An orbital movement is a peripheral motion of a body placed at a certain distance from a point around that point. When an electrode is attached inside the V notch in the electrode holder (9), the tool carries out an orbital movement and, additionally, does not change its angular position (i.e. does not turn about itself). The result is that the shape of the circumference of the tool is copied to the inside wall of the hole (this applies to bodies that have circular symmetry; e.g. a cylinder, a graduated cylinder, a cone as well as a tapping).

The accessory has an adjustment scale, which permits the size of the horizontal movement of the accessory to be set. There is no orbital movement when the screw is tightened. If the screw is loosened by one turn, the electrode will move horizontally by 1 mm and then stay at this diameter and execute an orbital turn. If, for example, the diameter of the electrode is 10 mm and that of the hole is 11 mm, then at the end of the process (an opening of 1 mm on the scale) a hole with a diameter of 12 mm will be obtained (in practice a little more - twice the spark gap has to be added to the dimension). Please note that the final diameter depends on the diameter of the electrode and on the scale setting and not on the diameter of the hole; i.e. even if the diameter of the hole were 10.8 or 11.5 mm, the final diameter will be 12 mm (with, as aforesaid, an opening [scale setting] of 1 mm).

During ordinary EDM sinking work, it is important that the return movement of the machine permits good flushing of the work area and removal of the minute particles that were detached from the material. The accessory maintains this feature of the machine and executes penetrations and withdrawals in accordance with the settings made by the operator. The withdrawal of the electrode will always be towards the centre of the hole and not back in the direction from which it came thus, forming a large gap and an effective flushing. As in ordinary work, if an operation is carried out in a blind hole it is better to make the flushing fluid to flow through a hole passing along the entire length of the electrode. Since the electrode in the accessory has a horizontal motion, a rigid pipe must not be used to join it, as this will interfere with the correct movement. The solution for this is a fluid inlet mechanism that is connected to the tool holder and firmly attaches an especially flexible tube to the electrode and is connected at its other end to the upper part of the accessory that is attached to the head of the machine – This is the only allowed method that fluid can flow to the electrode.

Forming a tapping: when a tapping is made using the EDtapper, at first a pilot hole has to be made, as for any tapping, in accordance with the standard tables of tapping drill size. The electrode, on the other hand, differs in its dimensions from a tap. The tapping pitch is the same as the regular one but the diameter of the electrode is significantly smaller than that of a tap. The diameter of the electrode has to be smaller than the pilot hole in order to form a sufficient gap that will allow good flushing.

Another difference is that when forming a tapping with a tap - a turning motion is used to make one winding after another to the desired depth. The tap is turned in the material according to the number of the required threads. In contrast, the EDtapper forms the whole depth of the tapping in a single orbital movement (resembling the milling of a tapping by a CNC machine - but without the need for advancing the tap pitch).

At first, the electrode has to enter the pilot hole to the desired depth and then base foot touching the machine table is locked [in position] and fixes the electrode on the Z-axis. The next stage is to determine, using the scale, the extent of the horizontal movement and thus the shape of the thread pitch on the electrode will be copied peripherally onto the walls of the hole.

Whenever the accessory is operated, it should be treated as if it was an ordinary EDM sinking job and the known methods - for coarse etching, measuring, adding horizontal movement, fine etching, measuring again and correcting if necessary - should be used. **The difference is that additional erosion is attained not by lowering the head of the machine to a greater depth but by [making use of] the horizontal movement scale.**

Figure 1 Depicts the EDtapper components.

Figure 2 Depicts the EDtapper kit contents.

Figure 3 Details the EDtapper Technical Specifications.

NOTE

TO FACILITATE PARTS IDENTIFICATION – A SINGLE CALLOUT NUMBER IS ASSIGNED TO THE PART IN ALL FIGURES.

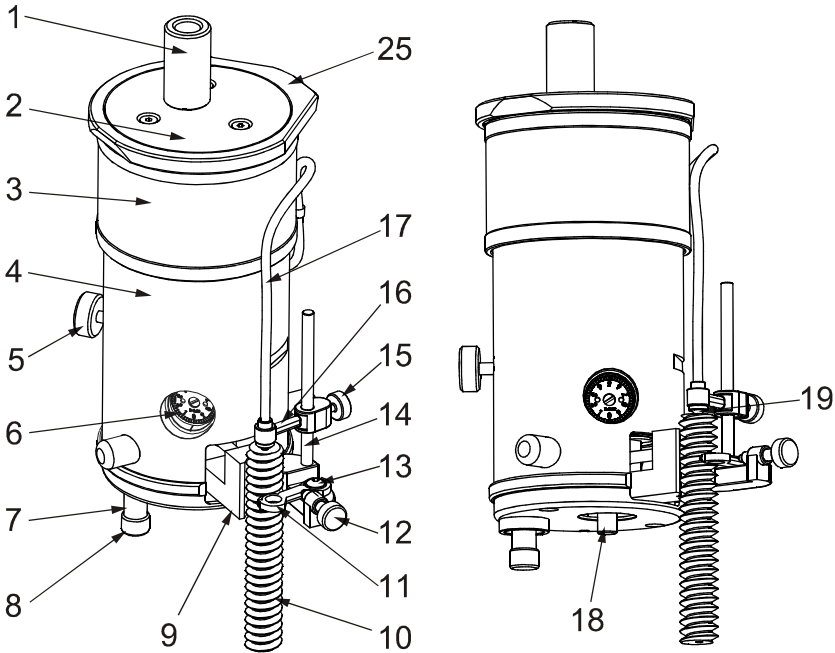

- | | | | |
|-----|--------------------------------|-----|--|
| 1. | Shank | 11. | Electrode mounting blade |
| 2. | Plate for attachment to magnet | 12. | Electrode tightening knob |
| 3. | Cover | 13. | Blade Attaching Screw |
| 4. | Accessory body | 14. | Hose holder rod |
| 5. | Foot fixing knob | 15. | Hose holder knob |
| 6. | Horizontal movement scale | 16. | Hose holder |
| 7. | Base foot | 17. | Flushing hose |
| 8. | Insulating cap | 18. | Electrode mounting Shaft |
| 9. | Electrode holder | 19. | Hose nozzle |
| 10. | Electrode | 25. | Securing ring for magnetic holder (compatible with 3R holders) |

Figure 1. EDTapper Accessory Description

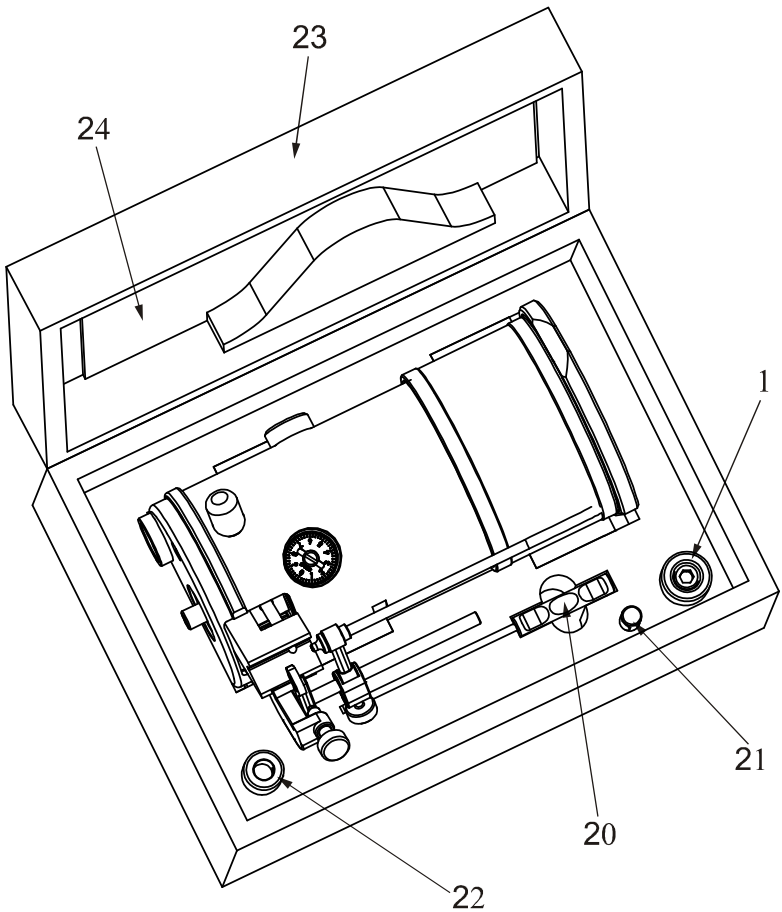

- 20. Scale key
- 21. 42 mm gauge
- 22. Electrode-to-Shaft attachment
- 23. EDtapper container
- 24. User's Manual

Figure 2. EDtapper Kit Contents

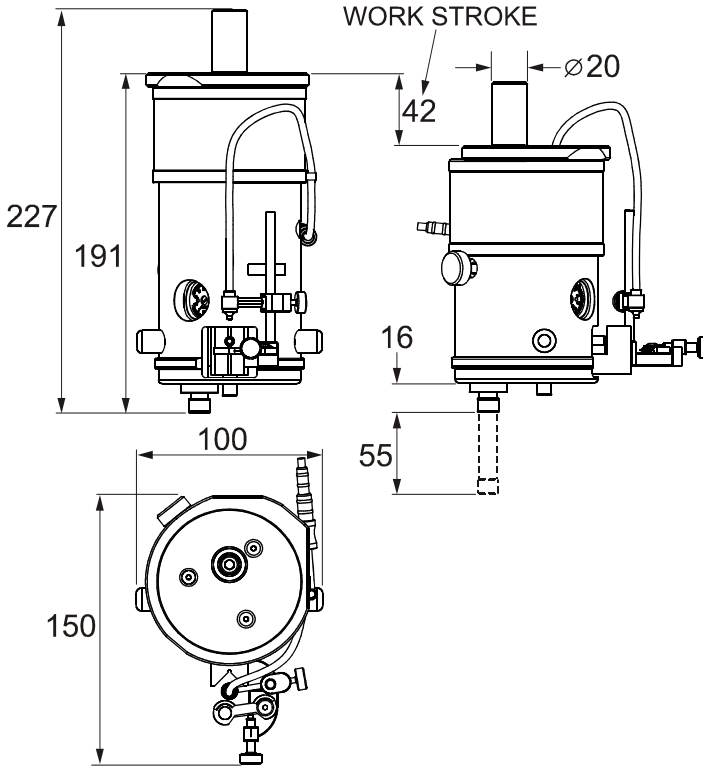

Weight:	1.7 kg
Force resisting head movement:	8 kg
Maximum electrode weight:	1 kg
Completion of orbital turn:	42 mm on Z-axis (40 mm + 2 mm overlapping)
Radial feed movement:	3.2 mm
Maximum thread pitch that can be formed	5 mm or 5 T.P.I.
Feed scale division:	0.02 mm
Foot stroke:	55 mm
Diameter of electrode rod for mounting in holder:	Ø 3 mm - Ø 20 mm
Maximum electrode diameter:	Ø 150 mm
Accuracy of tapping location in regard to hole:	±0.09 mm

Figure 3. EDtapper Technical Specifications

THIS PAGE INTENTIONALLY LEFT BLANK

Chapter 2

OPERATING INSTRUCTIONS

2-1. Normal Operational Procedure

2-1.1 General

The following steps detail the normal operation procedure.

- A. Connect surface (2) to magnetic holder and tighten securing latches on the two slants on ring (25). Alternatively, fasten shank (1) to surface (2) using the inner screw and attach to machine. See Figure 4.

NOTE

THE ACCESSORY MUST BE CONNECTED TO THE MACHINE IN A POSITION PARALLEL TO THE Z-AXIS (THE SINKING AXIS). IF THE CONNECTION POINT IS NOT RIGID (I.E. CAN BE ADJUSTED BY MEANS OF ALIGNMENT SCREWS) IT MUST BE ALIGNED, USING A GAUGE ON THE PLATE FOR ATTACHMENT TO MAGNET (2).

- B. Measure the diameter of the tapping electrode (10) on thread (\varnothing d). (A pilot hole must be made (by drilling or etching), according to the standard tables of tapping drill size, before forming the tapping)
- C. Position the tapping electrode in the electrode holder (9) and tighten using knob (12). Blade (11) is designed to attach the electrode on its shank or while engaged into one of its thread grooves. (The blade has to be reversed for fine tapping with a pitch smaller than 1 mm (24 T.P.I.)- see notes and advantages in para. 2-2.1).
- D. Ascertain that the horizontal movement scale screw (6) is tightened (clockwise) and that the scale indicates 0. If not, gently tighten, clockwise, using provided key (20) without applying force (No other key may be used!).

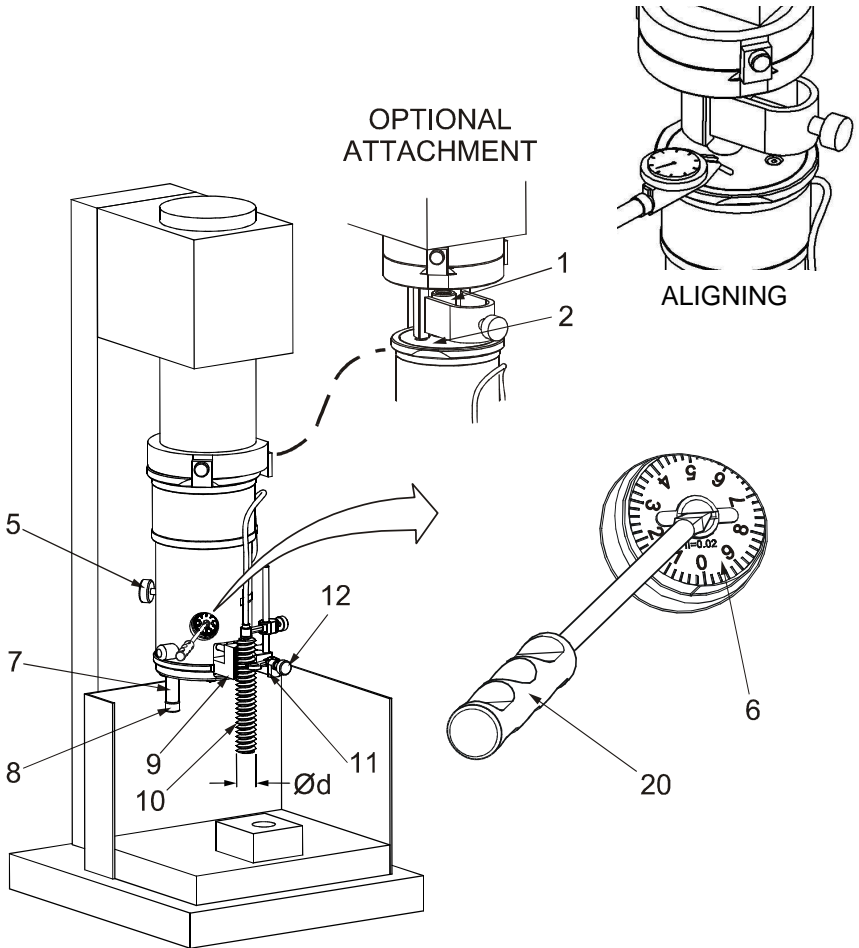

Figure 4. EDtapper Operation

- E. Lower the head of the machine until the electrode touches the surface from which the depth of the thread is measured and mark as zero on the depth gauge of the machine.
- F. Position the electrode inside the hole to be tapped by lowering the head of the machine together with the EDtapper and find its centre.

IMPORTANT!

THE HORIZONTAL MOVEMENT SCALE SCREW (6) MUST BE TIGHTENED BEFORE EACH POSITIONING OPERATION. FOR EXAMPLE, WHEN FORMING SEVERAL THREADS ON ONE PLATE, THE HORIZONTAL MOVEMENT SCALE SCREW (6) MUST BE TIGHTENED FOR EACH FINDING OF A HOLE'S CENTRE. IT IS NOT NECESSARY TO TIGHTEN THE SCALE ONLY IF THE DISTANCE BETWEEN THE HOLES IS KNOWN AND THE LOCATING IS DONE IN ACCORDANCE WITH COORDINATES (AFTER CENTERING OF THE FIRST HOLE WITH SCALE TIGHTENED).

- G. Lower the head of the machine so that the electrode penetrates the hole to the required depth for forming the tapping - observe that the EDtapper does not touch anything. Mark as a new zero.
- H. Release the foot fixing-knob (5) and pull the base foot (7) down until insulator (8) touches the machine table or the machined part itself (if the distance is too great insert a metal block with parallel sides, to obtain the required height). Hand tight the foot fixing-knob (5) well.

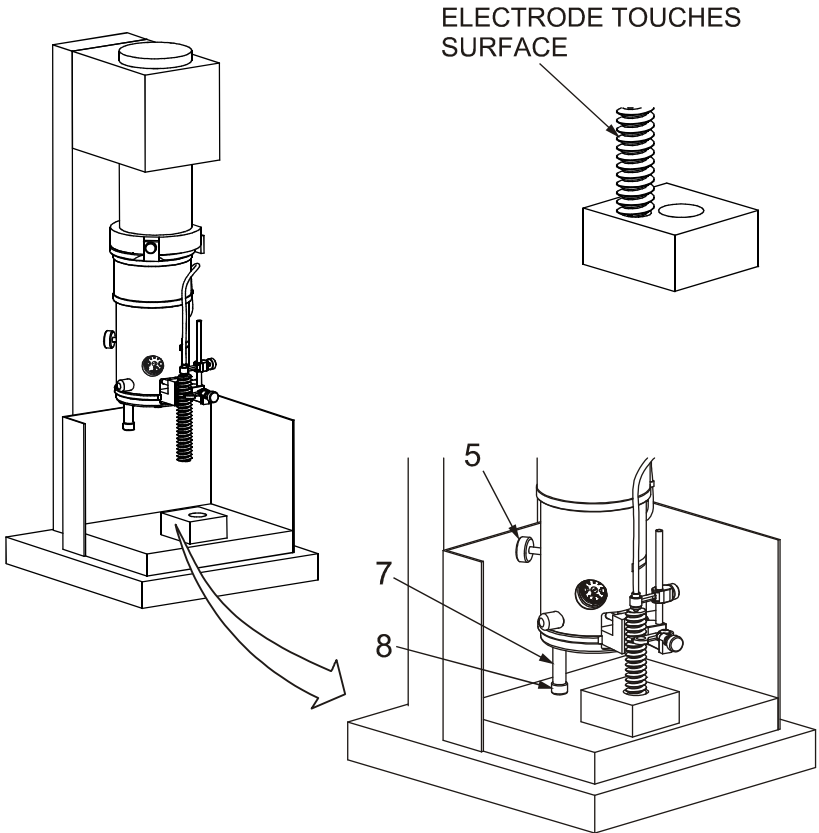

Figure 4. EDtapper Operation (Cont'd)

NOTE

THE HEAD OF THE MACHINE IS NOW POSITIONED WITH THE ELECTRODE AT THE DESIRED DEPTH INSIDE THE HOLE TO BE TAPPED AND THE FOOT OF THE EDTAPPER IS TOUCHING THE MACHINE'S TABLE. **THE DEPTH CONTROL (END OF OPERATION) HAS TO BE ADJUSTED SO THAT THE MACHINE HEAD CAN DESCEND ANOTHER 42 MM.**

- I. The datum 42 is fed digitally into some machines, for others the provided gauge (21) can be used. Insert gauge (21) between the dog (B) and the indicator rod, move dog (B) until "end of operation" light (A) illuminates, tighten **and remove gauge (21)!!**

WARNING

WITHOUT CORRECT ADJUSTMENT OF INTERRUPTION THE MACHINE OPERATION AFTER DESCENDING 42 MM, A SITUATION IS LIABLE TO ARISE IN WHICH THE MACHINE DESCENDS AND ENCOUNTERS MECHANICAL RESISTANCE WHEN THE ACCESSORY IS COMPLETELY CONTRACTED (THERE ARE ABOUT 3 MM MORE FOR SAFETY). THIS SEVERE SITUATION WILL CAUSE THE MACHINE TO BE SWITCHED OFF BY THE MACHINE PROTECTION MECHANISM (OVERLOAD).

- J. Calculate the horizontal movement (f) according to the equation and turn the scale screw (counterclockwise) accordingly:

NOTE

THE PILOT HOLE DIAMETER IS NOT A PARAMETER THAT INFLUENCES THE FINAL RESULT. THEREFORE, IT IS NOT PART OF THE EQUATION.

$$f = (\text{ØD} - \text{Ød})/2 - g$$

Where:

- D Is the outer diameter of the tapping to be formed
- d Diameter of the electrode
- g Spark gap according to the machine's data
- f Horizontal movement to be set on the scale

For example, if an M10 tapping is required and the electrode diameter is 7.8 mm and the spark gap is 0.1 mm, the scale screw has to be turned for a horizontal movement of 1 mm; i.e. one turn (the divisions on the scale represent 0.02 mm).

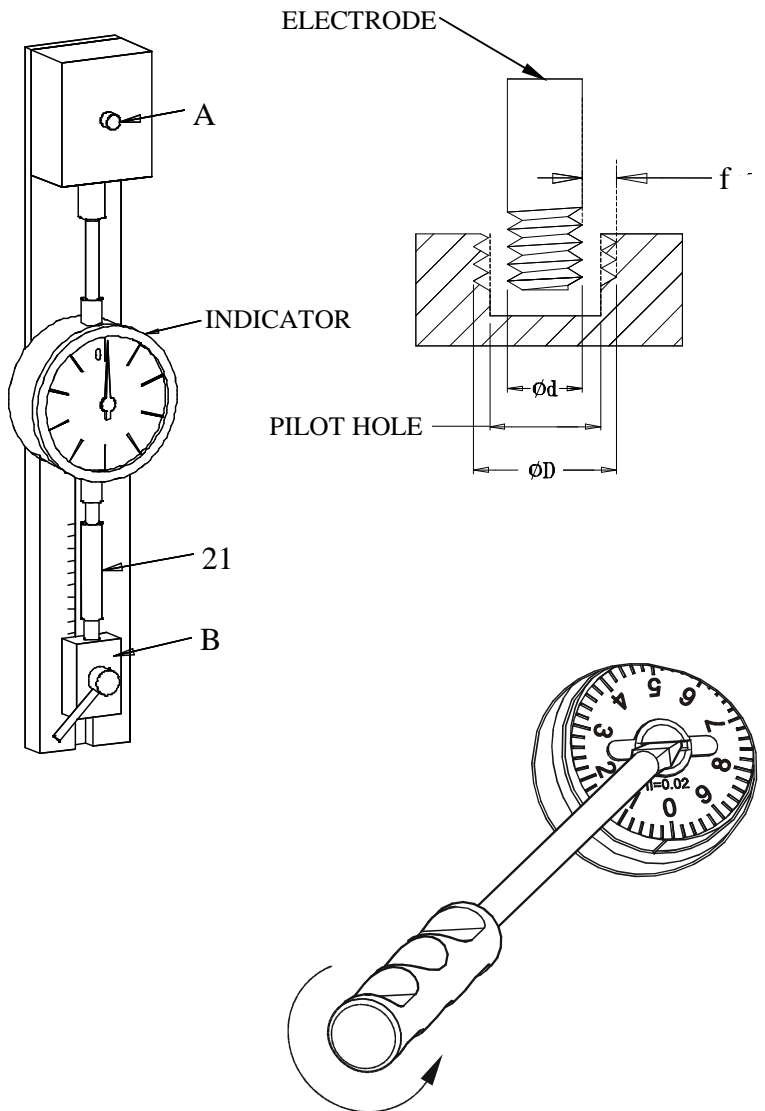

Figure 4. EDtapper Operation (Cont'd)

CAUTION

OBSERVE THE DIELECTRIC FLUID SPRAY NOZZLES BEFORE OPERATING THEM TO ENSURE THAT THEY ARE POINTING IN THE DESIRED DIRECTION. VERIFY THAT THERE WILL BE NO SPRAYING ONTO THE ACCESSORY.

- K. The EDtapper is ready for work - operate the machine and adjust the level of the immersing fluid and the working conditions. The immersing fluid level should cover the work area as for a regular sinking. The fluid level **must not** exceed the height of the accessory's base!

WHILE THE DEVICE IS WORKING THE SCALE DISAPPEARS AND A DOWNWARD SPIRAL LINE SHOWS THE PROGRESS OF THE PROCESS.

- L. If the hole is blind, fluid must be passed through the hole along the centre of electrode (10): release hose holder knob (15), lower the hose holder (16) along the rod (14) and position the hose nozzle (19) to be opposite the hole in the electrode (the hose holder can be moved in or out of it's housing to align the nozzle with the electrode hole) - tighten knob (15) while pressing flushing hose (17) to the upper part of electrode (10). Verify that the movement of the section of flushing hose (17) from electrode (10) to the connection point in the cover (3) is not obstructed. Connect the machine fluid outlet hose to the universal connector at the other side of the flushing hose (17) and fix with clamp if needed.
- M. It is recommended to initially carry out coarse etching, followed by measurement, a small increment on the scale (6) and fine etching to final dimensions.
- N. After use and before dismantling the accessory from the machine clean all parts of the accessory by wiping with a dry cloth. Do not use air gun for cleaning.

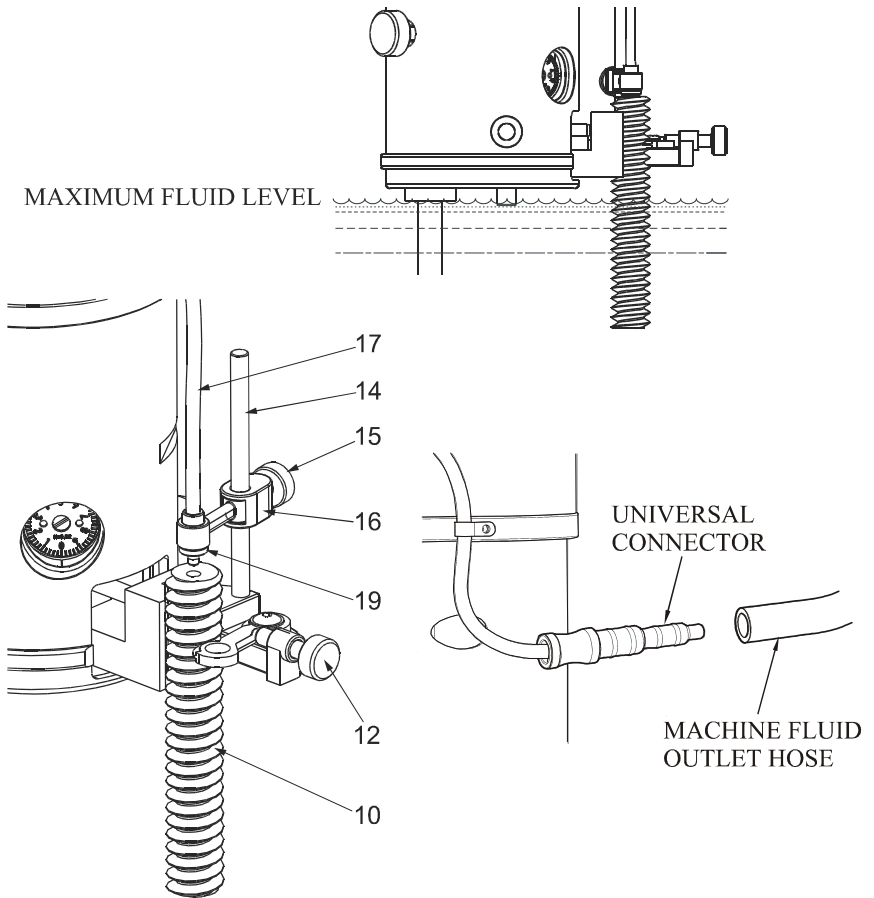

Figure 4. EDtapper Operation (Cont'd)

2-2. Special Operational Procedure

2-2.1 Adjusting The Blade For The Thread Pitch

Blade (11) is designed to hold the electrode in place when engaged in one of the electrode grooves (see Figure 5). The advantage of holding the electrode in this manner is that, it can be replaced with a new one and still know for certain that there will be no cross threading. The new threading may be deeper or shallower than the original one. Yet, as long as blade (11) penetrates an electrode's groove, there will be no cross threading. Blade (11) is provided with two profiles to ensure suitable engagement in electrode's groove (see Figure 6).

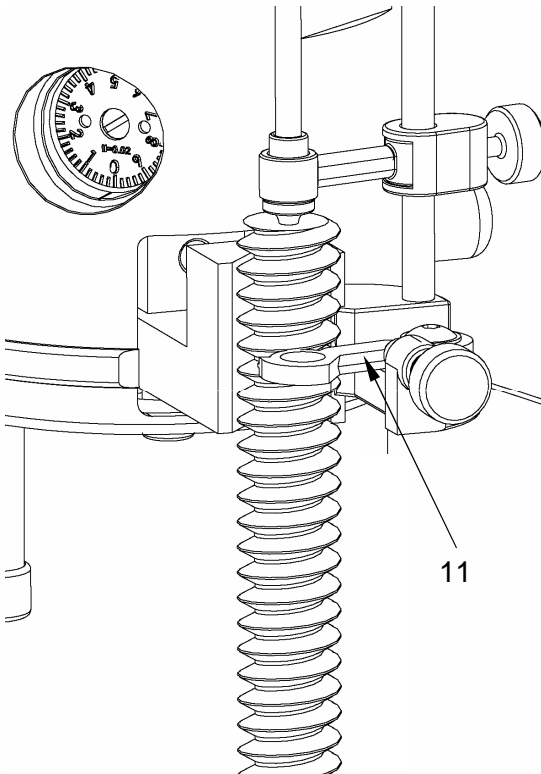

Figure 5. Blade Engaged in Electrode's Groove

- A. Release screw (13), release blade (11) and reverse it, making sure that the appropriate profile, faces the electrode holder (9). See Figure 6.

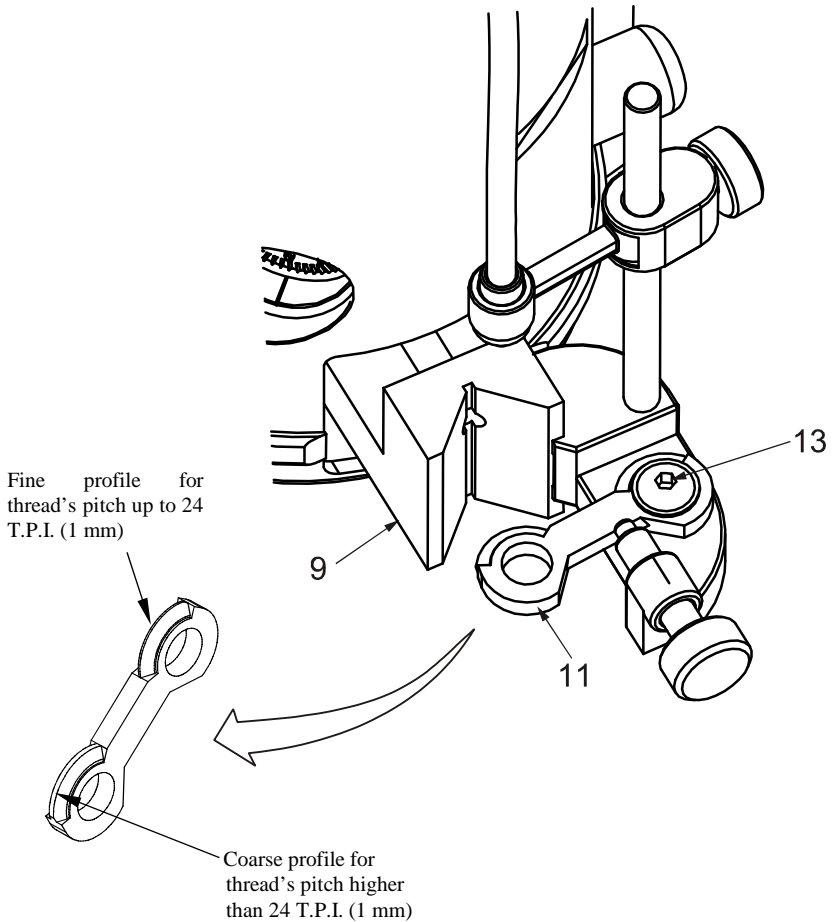

Figure 6. Blade Adjustment to fit Thread Pitch

2-2.2 Linear Motion Parallel To A Radial Alignment Surface

Forming an undercut for moulds, letters on a vertical sidewall, etc. See Figure 7.

- A. Verify that horizontal movement scale (6) screw is tightened.
- B. Check alignment, using indicator gauge connected to the machine's table (alignment surface indicated by the arrow in the figure) and adjust by turning the whole EDtapper so that the alignment surface is parallel to the machine's Y-axis.
- C. Install the required electrode and align its side parallel to Y-axis (now the electrode and the radial alignment surface are aligned as well).
- D. Position the accessory so that the electrode is at the required height and in the correct place on the X-axis. In Y-axis, bring the accessory close to the machined part until it almost touches it. Pull and fix the foot (see para. 2-1, step H).
- E. Turn the scale to an opening of 3.2 mm in order to permit the electrode to move up-to 3.2 mm on the Y-axis. However, a maximum (accurate) linear motion of 2 mm is available.

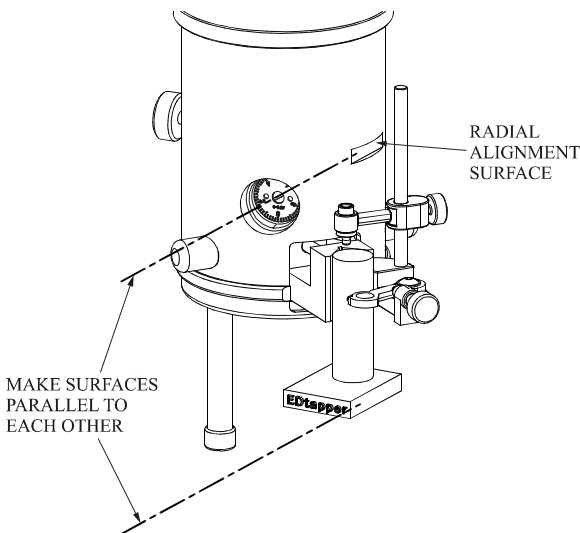

Figure 7. Linear Motion Parallel To A Radial Alignment Surface

IMPORTANT!

THE HEAD OF THE MACHINE MUST NOT BE ALLOWED TO DESCEND 42 MM, CONTRARY TO THAT EXPLAINED FOR FORMING A THREAD. THE MAXIMUM DESCENT ON THE Z-AXIS WHICH WILL CAUSE THE MAXIMUM AVAILABLE LINEAR MOVEMENT (3.2 MM) IS 1.6 MM.

- F. Adjust the depth control according to the table that gives the ratio of the head movement on the Z-axis to the linear movement of the electrode on the Y-axis:

Descent on Z-axis in mm	Movement on Y-axis in mm
0.5	1
1.0	2

For example: when forming a 0.4 mm deep stamp on a wall the machine must be allowed to descend 0.2 mm only.

2-2.3 Forming Cavities With A Circular Symmetry Using Flat Electrode With A Profile

The electrode is attached to electrode mounting shaft (18) using the electrode to shaft attachment (22) or similar accessory. Attachment to this point will cause the electrode to move from the centre in accordance with the adjustment of the scale (6) and then to rotate about itself. A cavity having circular symmetry will be obtained in accordance with the shape of the profile. See Figure 8.

- A. Install electrode to shaft attachment (22) on electrode mounting shaft (18) and turn it so that the slot for the electrode will be parallel to the radial alignment surface (see Figure 8).
- B. Find the centre of the hole, which you wish to form.
- C. Fit the electrode into the slot of the electrode to shaft attachment (22).
- D. Bring the electrode to the desired depth.
- E. Pull the foot until it touches the table and tighten.
- F. Adjust the depth control so that the machine can descend 42 mm.
- G. Release the scale as required.

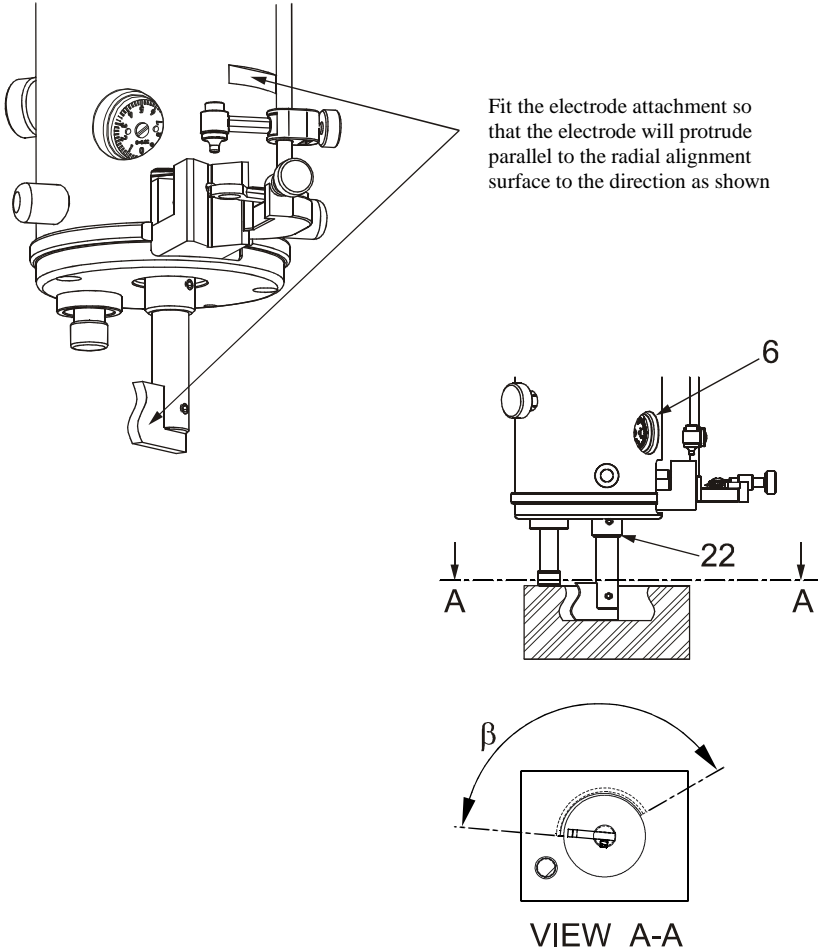

Figure 8. Forming Cavities With A Circular Symmetry Using Flat Electrode With A Profile

2-2.4 Partial (Less Than 360°) Sector Etching

Etching such as described in para. 2-2.3 can also be carried out on a partial sector (less than 360°) by restricting the descent of the head before it completes a whole turn. In order to obtain a profile on a sector β the descent of the head must be set, instead of 42 mm to a Z dimension according to the following calculation:

$$Z = \beta/9 + f/2$$

Where:

β is the desired angle in degrees and

f is the horizontal movement

If, for example, β equals 45° the descent of the head must be adjusted to 5 mm. If the horizontal movement scale is adjusted to a horizontal movement of 2 mm, the descent of the head must be adjusted to 6 mm.

2-2.5 Creation of Threads Using Short Electrode

Creation of threads in deep locations using a short electrode can be effectuated using a collet chuck (26). A dedicated collet chuck (26), with a rubber adapter (27) that allows dielectric fluid flowing through it to the electrode, may be purchased. See Figure 9.

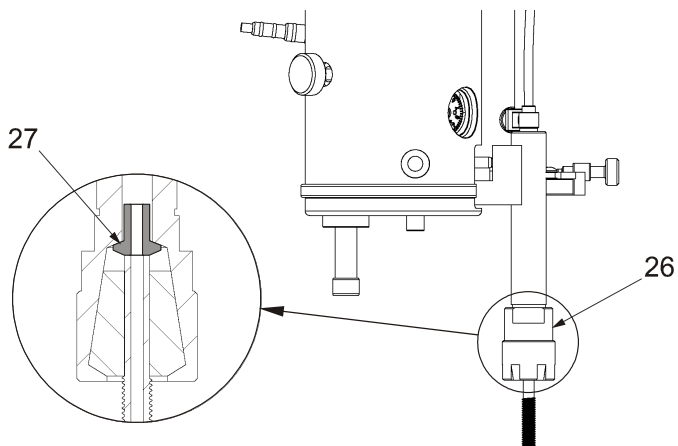

Figure 9. Using Collet Chuck

Chapter 3

CAUTIONS AND LIMITATION OF WARRANTY

1. Safeguard the accessory and store it in the box provided. Dropping the accessory is liable to cause damage that will not permit further proper operation - and will require repair.
2. After every use clean the accessory, in a vertical position before removing it from the machine, using a dry cloth to wipe the parts wetted by the dielectric fluid.
3. Empty the fluid from the hose before placing the accessory in the box.
4. **Do not use air gun for cleaning!**
5. Wipe the foot before retracting it.
6. No part whatsoever of the accessory may come into contact with the part being machined, the table or the bath - this will engender a spark and mutual etching [erosion] - only the electrically insulating cap on the bottom of the foot is meant to be anchored on the table.
7. Do not move the machine table when the base foot is fixed against it. For any change in the positioning of the table ensure that the base foot is not touching anything and does not bump into anything.
8. The accessory's operation is possible only when it is perpendicular to the table and parallel to the Z-axis.
9. Observe the dielectric fluid spray nozzles before operating them to ensure that they are pointing in the desired direction. Verify that there will be no spraying onto the accessory.
10. Check the level of the fluid and ensure that it does not surpass the bottom of the accessory - ingress of fluid containing particles of eroded material is liable to adversely affect the accessory (see para. 2-1, step K).
11. Care must be exercised to allow the head of the machine to descend a maximum of 42 mm from the moment that the insulated foot touches the table. Without correct adjustment, causing machine's operation to stop after a descent of 42 mm, the machine might descend and

encounter **mechanical resistance** when the accessory is fully contracted (there are about 3 mm more for safety). This severe condition will switch the machine off by means of the machine (Overload) protection mechanism.

12. Only the supplied scale key must be used to tighten the scale without applying force.
13. It is strictly forbidden to disassemble the accessory - any malfunction or problem should be referred to the service department.

Chapter 4

WARRANTY

We hereby guarantee the:

EDtapper - EDM tapping accessory for a sinker erosion machine (EDM).

For a period of 12 month from the supply date.

We hereby commit to replace or repair according to our decision, without further cost to the Buyer, any part that was proven faulty or non-usable.

This warranty is valid only for the direct Buyer whose name appears hereinafter.

This warranty is not applicable in case of malfunctions or damages to the EDtapper due to any of the following causes:

1. EDtapper usage contradicting operation instructions and/or warnings issued in the User's Manual provided with the EDtapper upon supply.
2. Force Major/breakage and/or accident.
3. Repair/disassembly/modification by unauthorized personnel.
4. EDM malfunction or unauthorized modifications to EDM, performed without manufacturer's consent or by unauthorized personnel.
5. Malicious or negligent actions performed by any other than the warranty issuer, representative or authorized repair shop.

In case of EDtapper inappropriate function, stop activity immediately and inform SHILO TECHNOLOGIES LTD. service department reporting EDtapper details and malfunction character.

We state explicitly that this warranty covers only the EDtapper repair or replacement cost.

In no event shall SHILO TECHNOLOGIES LTD. be liable for indirect, incidental or consequential damages of any kind due to inappropriate function of the EDtapper.

Nor shall the liability of SHILO TECHNOLOGIES LTD. arising in connection with any EDtapper sold hereunder (whether such liability arises from a claim based on contract, warranty, or otherwise) exceed the actual amount paid by Buyer to SHILO TECHNOLOGIES LTD. for the EDtapper delivered hereunder.

WARRANTY CARD FOR

EDtapper

EDM TAPPING ACCESSORY

PAT. PEND

12 month warranty as stipulated in the Warranty chapter of the
User's Manual.

Serial Number: _____

Purchase Date: _____

Buyer: _____

Buyers Address: _____

Retailer/Representative: _____

Cut and Fax to: +972-3-7601136

or

Scan and eMail to: ed-tapper@ed-tapper.com

Along with tax invoice that testifies on day of the purchase

THIS PAGE INTENTIONALLY LEFT BLANK

E!Dtapper

EDM TAPPING ACCESSORY

PAT. PEND

Serial Number: _____

Purchase Date: _____

Buyer: _____

Buyers Address: _____

Retailer/Representative: _____

SHILO TECHNOLOGIES LTD.

25 Haruvit st. Mishor A.I.Z., Jerusalem, ISRAEL 93510

Phone: +972-2-535-1416, Fax: +972-3-760-1136

www.ed-tapper.com

